

POWERMATIC®

PMPS-1600

PANEL SAW

PMPS-1600.....10000065M...1~400V, 50Hz

PMPS-1600-3...10000065T...3~400V, 50Hz

PARTS LIST

JPW Industries, Inc
427 New Sanford Road
LaVergne, Tennessee 37086
www.powermatic.com

P- PMPS-1600-3 / PMPS-1600

2020-07

1.0 Exploded Drawing of Machine Cabinet Assembly

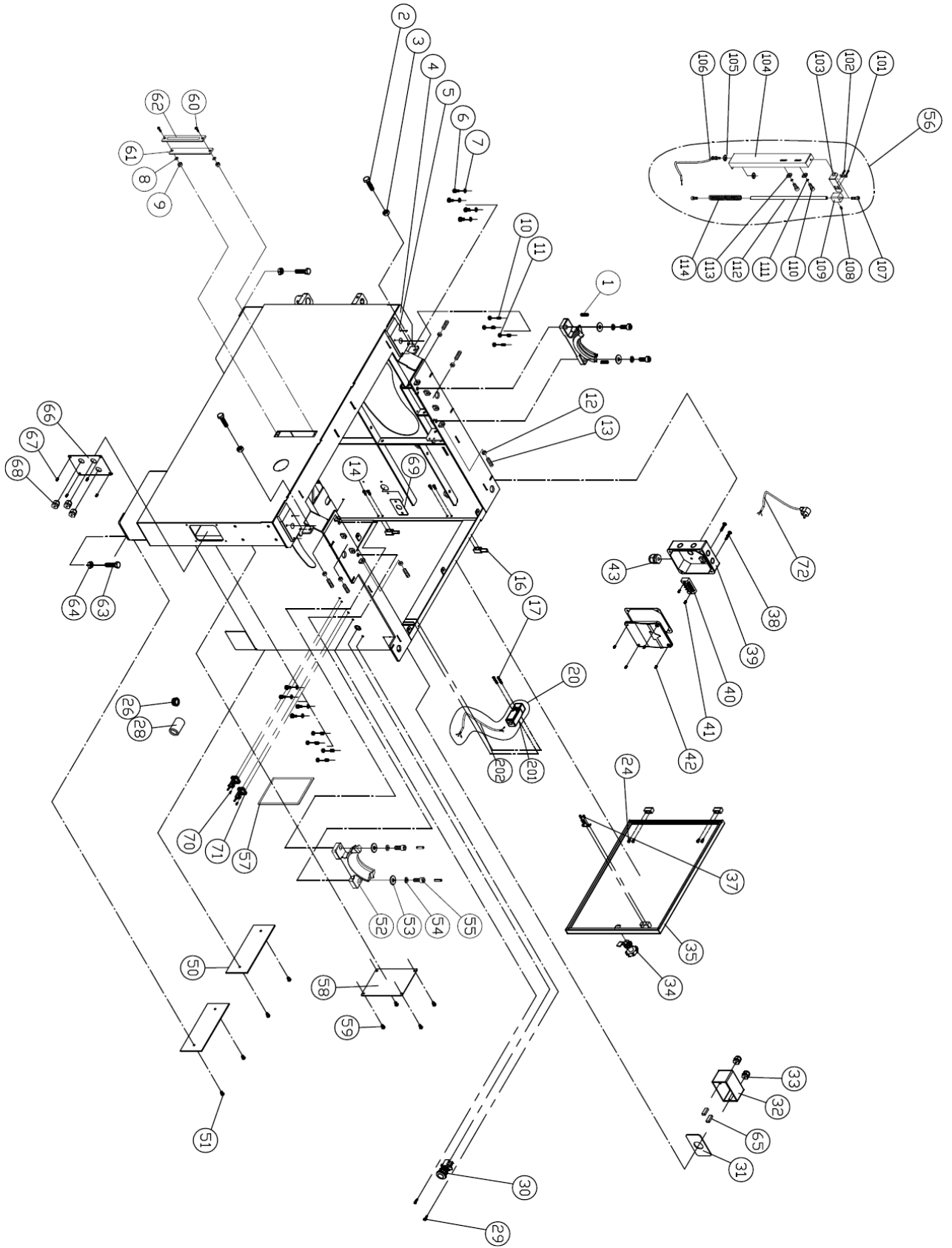

1.1 Parts list of Machine Cabinet Assembly

Index No.	Part No.	Description	Size	Qty.
1	JTSS3200X2-167	Roll Pin	Ø6x25	4
2	TS-1491061	Hex Cap Bolt	M10x40	2
3	TS-2311101	Hex. Nut	M10	2
4	PMPS-1600-104	Machine Main Frame		1
5	PMPS-1600-105	Table Mounting Plate		2
6	TS-1503031	Socket Head Cap Screw	M6x12	8
7	TS-2361061	Lock Washer	M6	8
8	TS-1550021	Flat Washer	M4	2
9	TS-1541001	Hex. Nut Nylon Lock	M4	2
10	TS-1523061	Socket Set Screw	M6x20	8
11	TS-1540041	Hex Nut	M6	8
12	TS-2311081	Hex Nut	M8	6
13	TS-1524061	Socket Set Screw	M8x25	6
14	TS-1534041	Hex Flange Screw	M5x10	4
16	JTSS3200X2-116	Door Hinge		2
17	SP040500	Pan Head Screw	M4x25	2
20	JTSS-3200X2-120	Cabinet Door Limit Switch Assembly		1
20-1	JTSS-3200X2-120-1	Cabinet Door Limit Switch	AZD-S11	1
20-2	JTSS-3200X2-120-2	Door Limit switch Cord	0.75mm ² x2Cx2Y2	1
24	SG059100	Hex Flange Screw	M5x6	4
26	JTSS3200X2-156	Hole Plugs	HP-22	1
28	JTSS1600X2-128	Sponge		1
29	ST050400	Tap Screw	M5x20	2
30	JTSS3200X2-136	Emergency Stop Button	R2PNR4-1B-R	1
31	JTSS3200X2-137	Gasket		1
32	JTSS3200X2-138	Switch Box		1
33	JTSS3200X2-139	Strain Relief		2
34	JTSS3200X2-140	Cabinet Door Lock		1
35	PMPS-1600-141	Cabinet Door		1
37	TS-2284082	Pan Head Screw	M4x8	2
38	TS-1534032	Pan Head Screw	M6x10	4
39	JTSS3200X2-145	Wiring Junction Box		1
40	JTSS3200X2-146	Terminal Block	PB2504 4P	1
41	ST040204	Tap Screw	M4x10	2
42	TS-1533062	Pan Head Screw	M5x20	4
43	JTSS3200X2-149	Strain Relief	PG20	2
50	PMPS-1600-150	Right Bottom Cabinet Panel		2
51	TS-1534032	Pan Head Screw	M6x10	4
52	JTSS3200X2-131	Blade Tilt Trunnion		2
53	TS-1550071	Flat Washer	M10xØ20	4
54	TS-2361101	Lock Washer	M10	4
55	TS-1505051	Socket Head Cap Screw	M10x35	4
56	JTSS3200X2-168	Steel Wire Assembly		1
56-1	TS-1550031	Flat Washer	M5	2
56-2	TS-1533032	Pan Head Screw	M5x10	2
56-3	JTSS3200X2-168-3	Pointer		1

Index No.	Part No.	Description	Size	Qty.
56-4	JTSS3200X2-168-4	Tilt Scale Bracket		1
56-5	TS-1550041	Flat Washer	M6	2
56-6	JTSS3200X2-168-6	Steel Wire		1
56-7	TS-1502021	Socket Head Cap Screw	M5x10	2
56-8	TS-1522031	Socket Set Screw	M5x10	1
56-9	JTSS3200X2-168-9	Pointer Bracket		1
56-10	TS-1503031	Socket Head Cap Screw	M6x12	2
56-11	TS-2361061	Lock Washer	M6	2
56-12	JTSS3200X2-168-12	Shaft		1
56-13	TS-1550041	Flat Washer	M6	2
56-14	JTSS3200X2-168-14	Compression Spring		1
57	JTSS3200X2-101	Panel Gasket	2x300x7.5 mm	2
58	PMPS-1600-112	Frame Rear Panel		1
59	TS-1534032	Pan Head Screw	M6x10	4
60	SF049400	Hex Head Cross flange screws	M4x16	2
61	JTSS3200X2-170	Scale Plate Cover		1
62	JTSS3200X2-171	Tilt Scale		1
63	TS-2213501	Hex. Cap Bolt	M16x50	4
	JTSS1600X2-163	Machine Main Frame Support Feet	M16x100	4
64	TS-154010	Hex Nut	M16	4
65	JTSS3200X2-184	Cord Connector	224-201	2
66	JTSS1600X2-166	Side Cord Panel		1
67	TS-2246122	Socket Button Head Screw	M6x12	4
68	JTSS3200X2-149	Strain Relief	PG20	3
69	PMPS-1600-169	Cord Plate		1
70	ST049300	Tapping Screw		4
71	JTSS3200X2-188	Hanger		2
72	JTSS1600X2-172	Power Cord with VDE 16A/250V CE Plug	3Cx1.5mm ² (1PH)	1

2.0 Exploded Drawing of Main Task Table & Extension Table Assembly

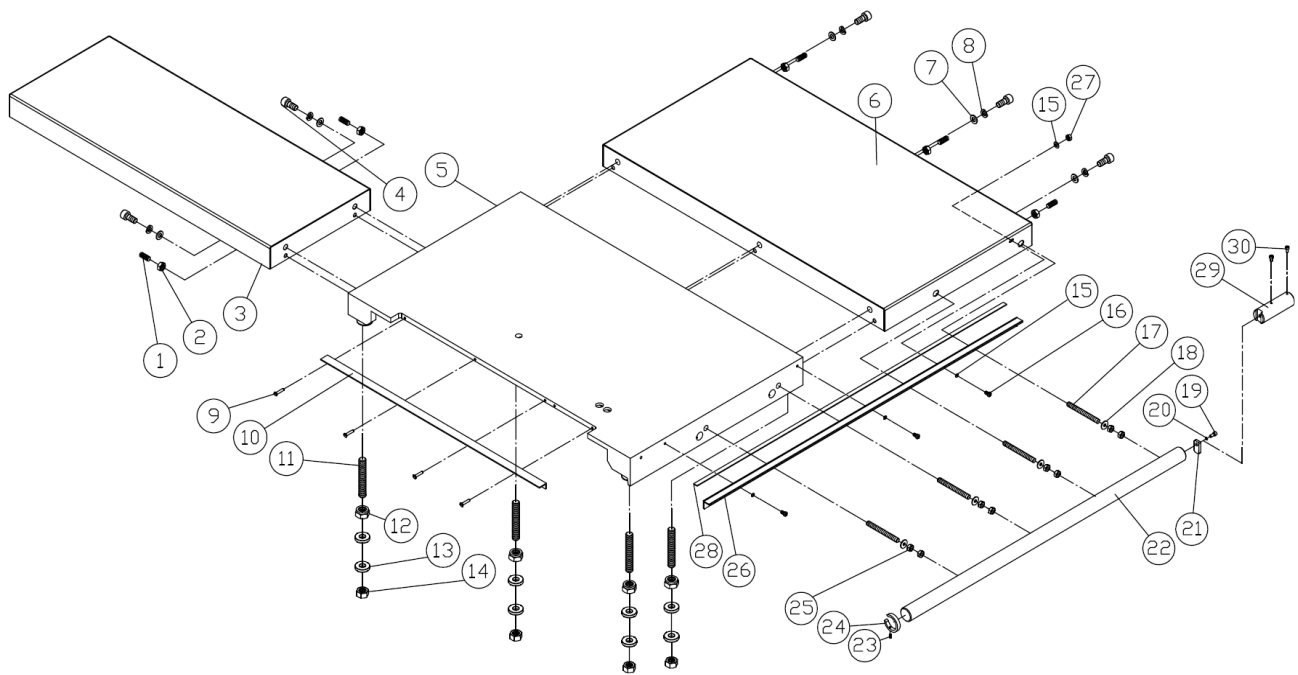

2.1 Parts list of Main Task Table & Extension Table Assembly

Index No.	Part No.	Description	Size	Qty.
1	TS-1525041	Socket Set Screw	M10x20	5
2	TS-2311101	Hex. Nut	M10	5
3	PMPS-1600-203	Left Extension Wing		1
4	TS-1505031	Socket Head Cap Screw	M10x25	5
5	PMPS-1600-205	Main Saw Table		1
6	PMPS-1600-206	Rear Extension Wing		1
7	TS-1550071	Flat Washer	M10	5
8	TS-2361101	Lock Washer	M10	5
9	TS-2246122	Socket Button Head Screw	M6x12	4
10	JTSS3200X2-210	Table Insert		1
11	208436	Socket Set Screw	M16*100	4
12	TS-2342161	Hex. Nut Nylon Lock	M16	4
13	JTSS3200X2-213	Table Mount Spacer	16 mm	8
14	TS-2311161	Hex. Nut	M16	4
15	TS-1550041	Flat Washer	M6	4
16	TS-2246122	Socket Button Head Screw	M6x12	3
17	JTSS3200X2-1406	All Thread Stud	M12x115Lx1.75P	4
18	WF132225	Flat Washer	M13	4
19	TS-1504031	Socket Head Cap Screw	M8x16	1
20	TS-2361081	Lock Washer	M8	1
21	JTSS3200X2-1410	Rip Fence Rail End Plate		1
22	JTSS1600X2-222	Rip Fence Round Rail		1
23	TS-1523031	Socket Set Screw	M6x10	1
24	JTSS3200X2-1413	Rip Fence Stop Ring		1
25	TS-1540081	Hex Nut	M12	8
26	JTSS1600X2-226	Scale Rail		1
27	TS-1540041	Hex Nut	M6	1

3.0 Exploded Drawing of Magnet Switch Assembly

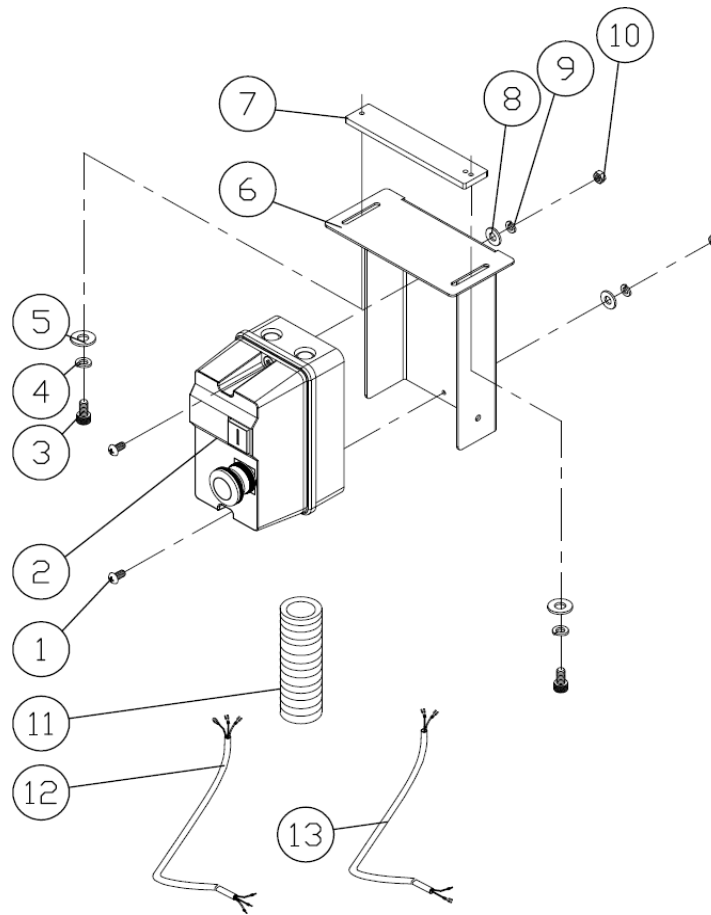

3.1 Parts list of Magnet Switch Assembly

Index No.	Part No.	Description	Size	Qty.
1	TS-1532052	Pan Head Screw	M4x16	2
2	PMPS-1600-302	Magnet Switch (black)	400V/50Hz/3PH	1
	PMPS-1600-302-1	Magnet Switch (black)	230V/50Hz/1PH	1
3	TS-1502041	Socket Head Cap Screw	M5x16	2
4	TS-2361051	Lock Washer	M5	2
5	TS-1550031	Flat Washer	M5	2
6	PMPS-1600-306	Switch Seat		1
7	JTSS1600X2-307	Locate Plate	M6	1
8	TS-1550021	Flat Washer	M4	2
9	TS-2361041	Lock Washer	M4	2
10	TS-1540021	Hex Nut	M4	2
11	JTSS-1600X2-311	Plastic Corrugated Tube	NF1-08B	1
12	JTSS-1600X2-312	Power Cord (400V/3PH)	4Cx2.5mm ²	1
	JTSS-1600X2-312-1	Power Cord (230V/1PH)	3Cx2.5mm ²	1
13	JTSS-1600X2-313	Stop Control Cord with limit switch	2Cx0.75mm ²	1

4.0 Exploded Drawing of Main Blade Trunnion

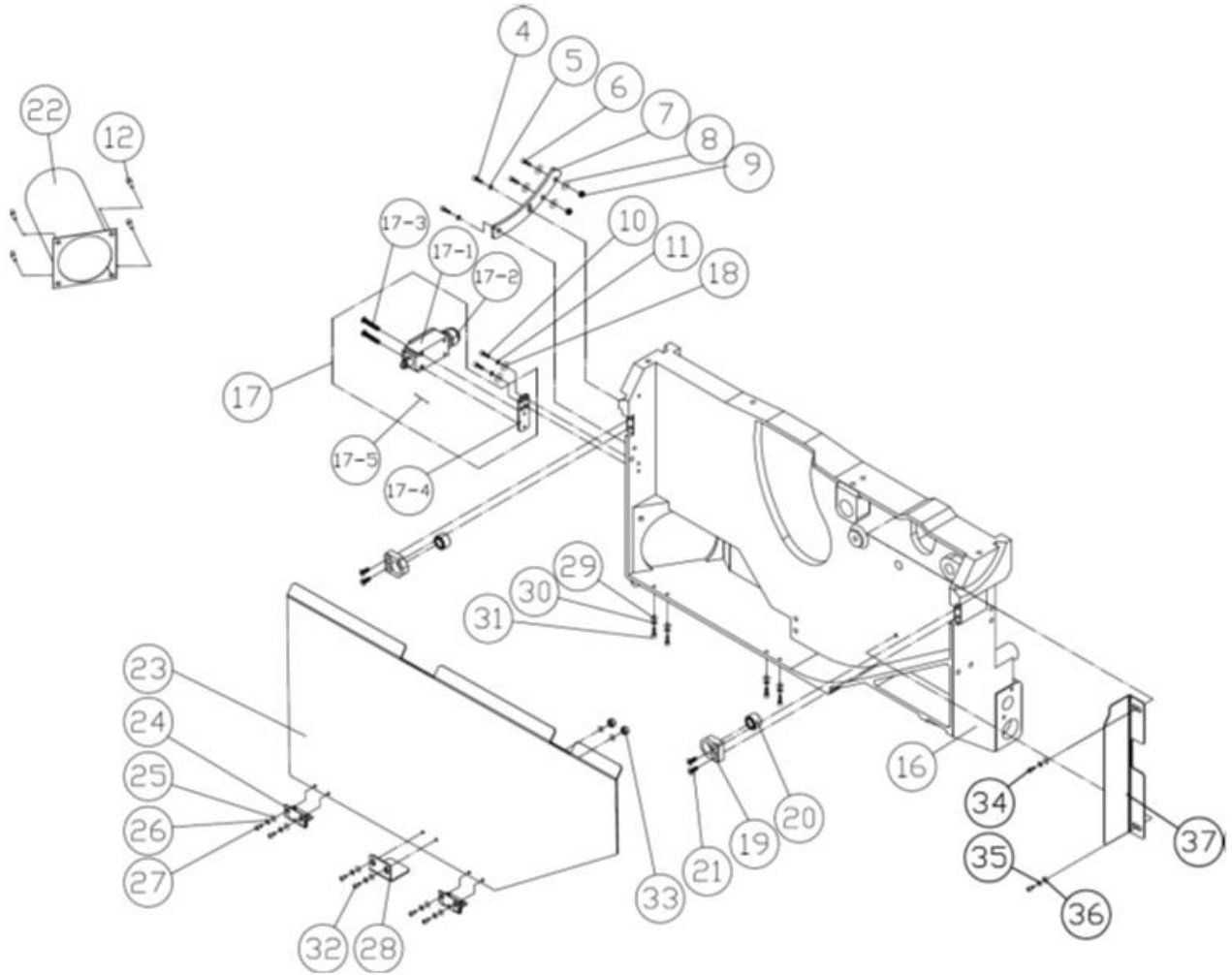

4.1 Parts list of Main Blade Trunnion

Index No.	Part No.	Description	Size	Qty.
4	TS-1503031	Socket Head Cap Screw	M6x12	2
5	TS-2361101	Lock Washer	M10	2
6	TS-1502041	Socket Head Cap Screw	M5x16	2
7	JTSS3200X2-407	Angle Plate		1
8	TS-1550031	Flat Washer	M5x10	4
9	TS-1541011	Hex. Nut Nylon Lock	M5	2
10	TS-1502031	Socket Head Cap Screw	M5x12	2
11	TS-2361051	Lock Washer	M5	2
12	TS-1481031	Hex. Cap Screw	M5x12	2
16	PMPS-1600-416	Elevation Trunnion		1
17	JTSS3200X2-417	Blade Cover Safety Switch Assembly		1
17-1	JTSS3200X2-417-101	Safety Limit Switch		1
17-2	JTSS3200X2-417-102	Strain Relief	PG-11	1
17-3	SP040700	Pan Head Screw	M4x35	2
17-4	JTSS3200X2-417-104	Safety Limit Switch Bracket		1
17-5	JTSS3200X2-417-105	Limit Switch Cord	0.75mm ² x2Cx2M	1
18	TS-1550031	Flat Washer	M5x10	2
19	JTSS3200X2-419	Magnet Holder		2
20	TS-2311161	Blade Cover Magnet		2
21	SM060400	Sunk Head Socket Screw	M6x20	4
22	PMPS-1600-422	Dust Port		1
23	PMPS-1600-423	Blade Cover		4
24	JTSS3200X2-424	Blade Cover Hinge		2
25	TS-1550031	Flat Washer	M5x10	8
26	TS-2361051	Lock Washer	M5	6
27	TS-1502011	Socket Head Cap Screw	M5x8	4
28	JTSS3200X2-428	Blade Cover Hinge Bracket		1
29	TS-1550031	Flat Washer	M5x10	4
30	TS-2361051	Lock washer	M5	4
31	TS-1502021	Socket Head Cap Screw	M5x10	4
32	TS-1502041	Socket Head Cap Screw	M5x16	2
33	TS-1540031	Nex. Nut	M5	2
34	TS-1503021	Socket Head Cap Screw	M6x10	2
35	TS-2361061	Lock Washer	M6	2
36	TS-1550041	Flat Washer	M6	2
37	JTSS3200X2-437	Blade Partition Plate		1

5.0 Exploded Drawing of Main Blade Motor & Drive Assembly

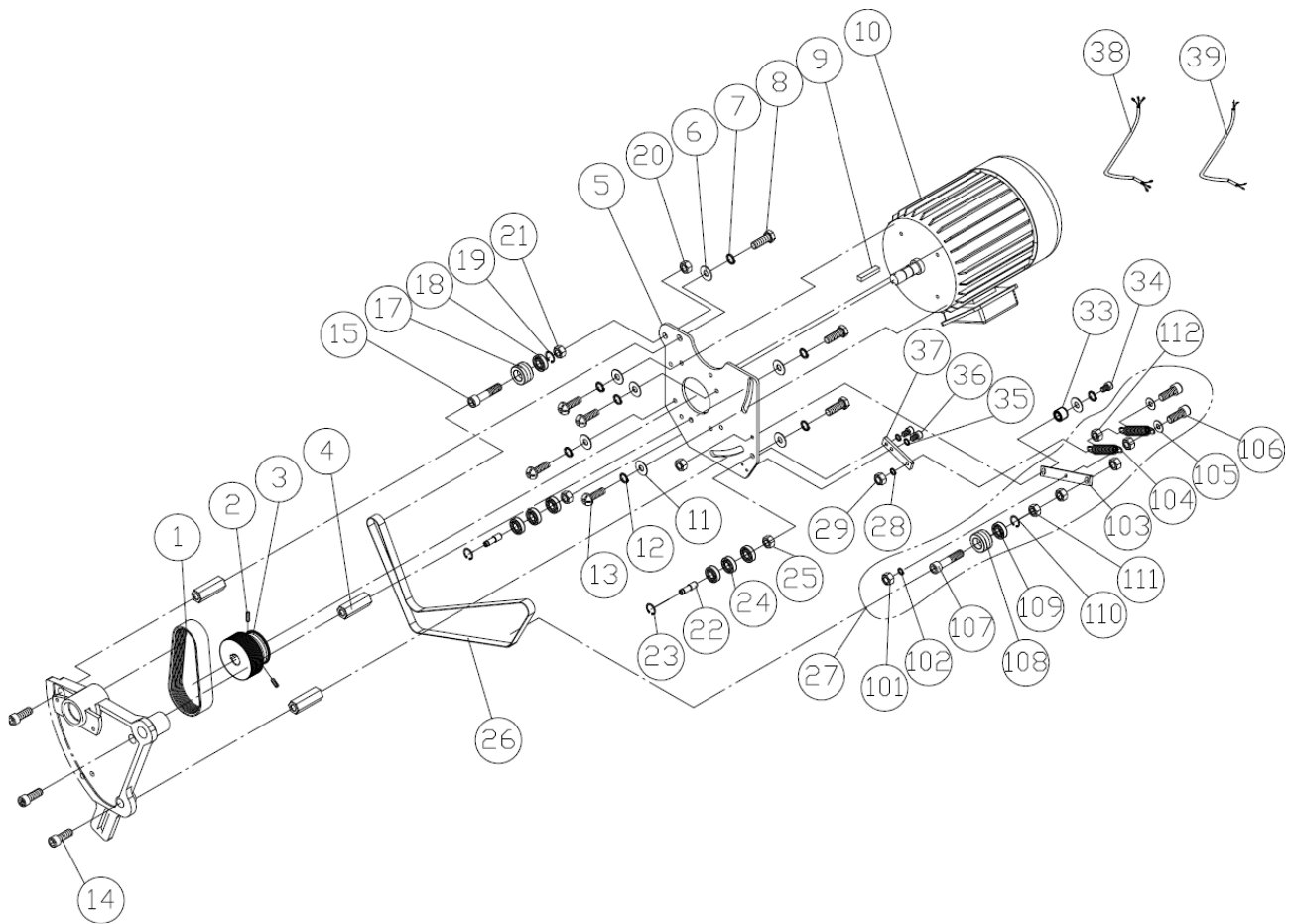

5.1 Parts list of Main Blade Motor & Driving Assembly

Index No.	Part No.	Description	Size	Qty.
1	JTSS1600X2-501	V-Belt	PJ-190	1
2	TS-1523021	Socket Set Screw	M6x8	6
3	JTSS1600X2-503	Motor Pulley		1
4	JTSS3200X2-504	Spacer	M10x25	3
5	PMPS-1600-505	Main Blade Mounting Plate		1
6	WF132225	Motor Mount Flat Washer	M13	3
7	TS-2361121	Lock Washer	M12	3
8	TS-1492031	Hex. Cap Screw	M12x35	3
9	JTSS1600X2-509	Key	8x7x40	1
10	PMPS-1600-510	Main Blade Motor	3.75KW 3PH 50Hz 400V..	1
	JTSS1600X2-510-1	Main Blade Motor	2.25KW 1PH 50Hz 230V..	1

11	TS-1550061	Flat Washer	M8	4
12	TS-2361081	Lock Washer	M8	4
13	TS-2208201	Hex. Cap Screw	M8x20	4
14	TS-1506031	Socket Head Cap Screw	M12x30	3
15	SR121100	Socket Head Cap Screw	M12x55	1
17	JTSS1600X2-517	Idler Pulley		1
18	BB600103	Bearing	6001LLU	1
19	JTSS3200X2-707-4	Ext. Retaining Ring	28 mm	1
20	TS-2342121	Hex. Nut Nylon Lock	M12	1
21	NH121904	Hex. Nut	M12xP1.75X6t	1
22	JTSS1600X2-522	Shaft		2
23	JTSS1600X2-523	C Ring	ϕ 10	2
24	BB620003	Bearing	6200LLU	6
25	NH121904	Hex. Nut	M12xP1.75X6t	2
26	JTSS1600X2-526	Belt		1
27	JTSS1600X2-527	Pivot Plate Assembly		1
27-1	NH081304	Hex Nut	M8*1.25P*t4	1
27-2	TS-2361081	Lock Washer	M8	1
27-3	JTSS1600X2-527-3	Pivot Plate		1
27-4	JTSS1600X2-527-4	Expansion Spring		2
27-5	TS-1550061	Flat Washer	M8	2
27-6	TS-1490071	Hex. Cap Bolt	M8x40	2
27-7	SR121100	Socket Head Cap Screw	M12x55	1
27-8	JTSS1600X2-517	Idler Pulley		1
27-9	BB600103	Bearing	6001LLU	1
27-10	JTSS1600X2-527-10	C Ring	ϕ 28	1
27-11	NH121904	Hex. Nut	M12xP1.75X6t	3
27-12	TS-1540061	Hex. Nut	M8	1
28	TS-2361081	Lock Washer	M8	2
29	TS-1540061	Hex. Nut	M8	1
33	JTSS1600X2-533	Bushing	M8	1
34	TS-1504051	Socket Head Cap Screw	M8x25	1
35	TS-1504051	Lock Washer	M6	2
36	TS-1503041	Socket Head Cap Screw	M6x16	2
37	JTSS1600X2-537	Fixing Plate		1
38	JTSS1600X2-538	Motor Cord (400V/3PH)	4Cx2.5mm ²	1
	JTSS1600X2-538-1	Motor Cord (230V/1PH)	3Cx2.5mm ²	1
39	JTSS1600X2-539	Brake Control Cord	2Cx0.75mm ²	1

6.0 Exploded Drawing of Main Blade Arbor Mechanism

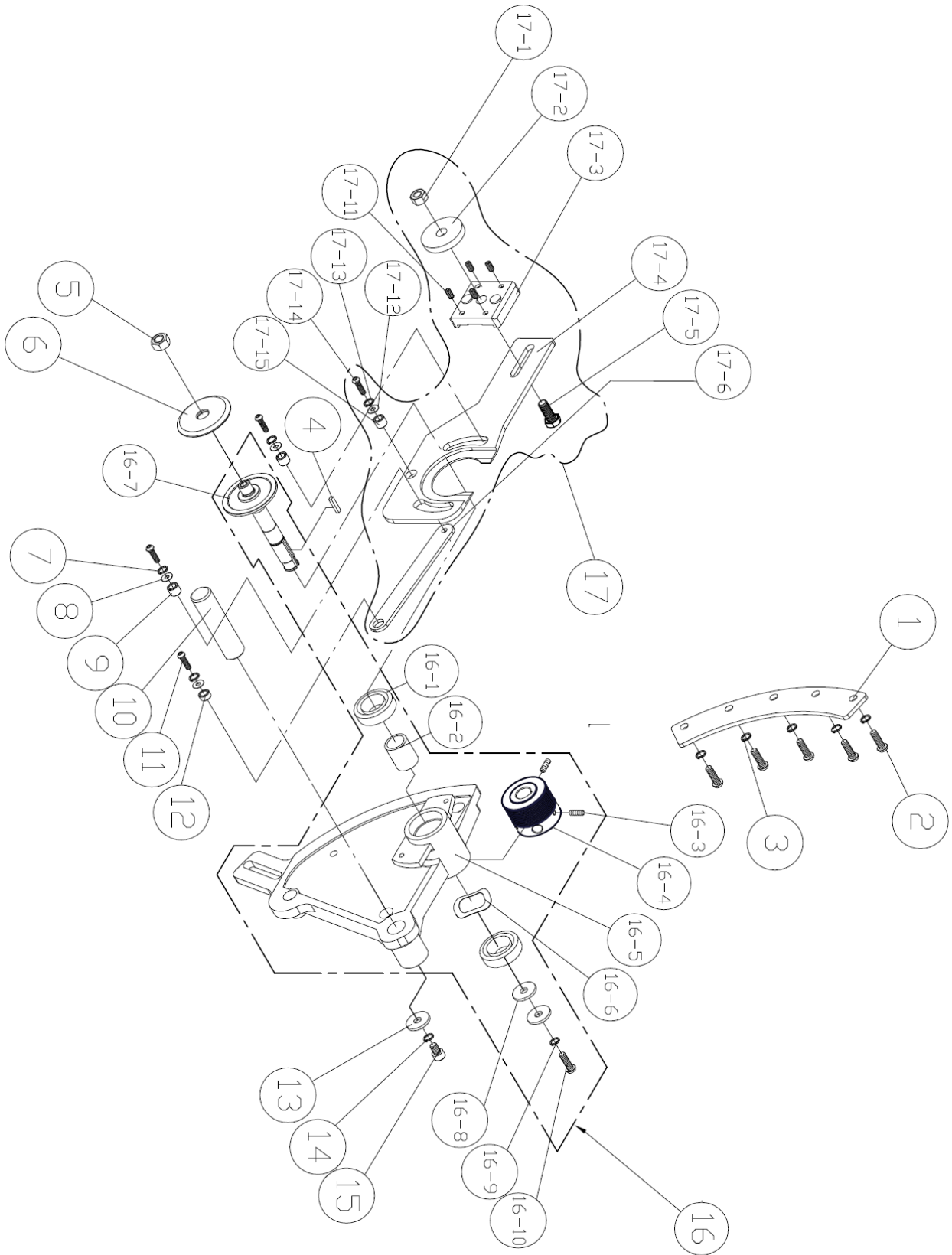

6.1 Parts list of Main Blade Arbor Mechanism

Index No.	Part No.	Description	Size	Qty.
1	JTSS3200X2-601	Gip Plate		1
2	TS-2249252	Socket Button Head Screw	M10x25	5
3	TS-2361101	Lock Washer	M10	5
4	JTSS3200X2-604	Double Round Flat Key	5x5x20	1
5	201822	Hex. Nut	M16x2 (left helix)	1
6	JTSS1600X2-606	Main Blade Arbor Flange	φ 30	1
7	TS-2361081	Lock Washer	M8	3
8	TS-1550061	Flat Washer	M8	3
9	JTSS3200X2-609	Bushing		3
10	JTSS3200X2-610	Arbor Housing Pivot Shaft		1
11	TS-2248202	Socket Button Head Screw	M8x20	3
12	JTSS3200X2-612	Bushing		1
13	TS-1550061	Flat Washer	M8	1
14	TS-2361081	Lock Washer	M8	1
15	TS-1490031	Hex. Cap Screw	M8x20	1
16	JTSS1600X2-616	Arbor Housing Assembly		1
16-1	BB-6206VV	Ball Bearing	6206 LLB	2
16-2	JTSS3200X2-616-2	Bearing Spacer		1
16-3	TS-1523021	Socket Set Screw	M6x8	3
16-4	JTSS1600X2-616-4	Main Blade Arbor Pulley		1
16-5	JTSS3200X2-616-5	Main Blade Arbor Housing		1
16-6	JTSS3200X2-616-6	Wave Washer	Ø47×Ø60	3
16-7	JTSS3200X2-616-7	Main Blade Arbor	Ø30	1
16-8	TS-1550061	Flat Washer	M8	2
16-9	TS-2361081	Lock Washer	M8	1
16-10	TS-2248202	Socket Button Head Screw	M8x20	1
17	JTSS3200X2-617	Riving Knife Bracket Assembly		1
17-1	TS-2311101	Hex. Nut	M10	1
17-2	TS-1550071	Flat Washer	M10	1
17-3	JTSS3200X2-617-3	Front Riving Knife Bracket		1
17-4	JTSS3200X2-617-4	Riving Knife Bracket		1
17-5	SC100700	Carriage Bolt	M10x35	1
17-6	JTSS3200X2-617-6	Pivot Link Plate		1
17-11	TS-1522031	Socket Set Screw	M5x10	4
17-12	TS-1550061	Flat Washer	M8	1
17-13	TS-2361081	Lock Washer	M8	1
17-14	TS-2248202	Socket Button Head Screw	M8x20	1
17-15	JTSS3200X2-612	Bushing		1

7.0 Exploded Drawing of Tilt Hand-wheels Mechanism

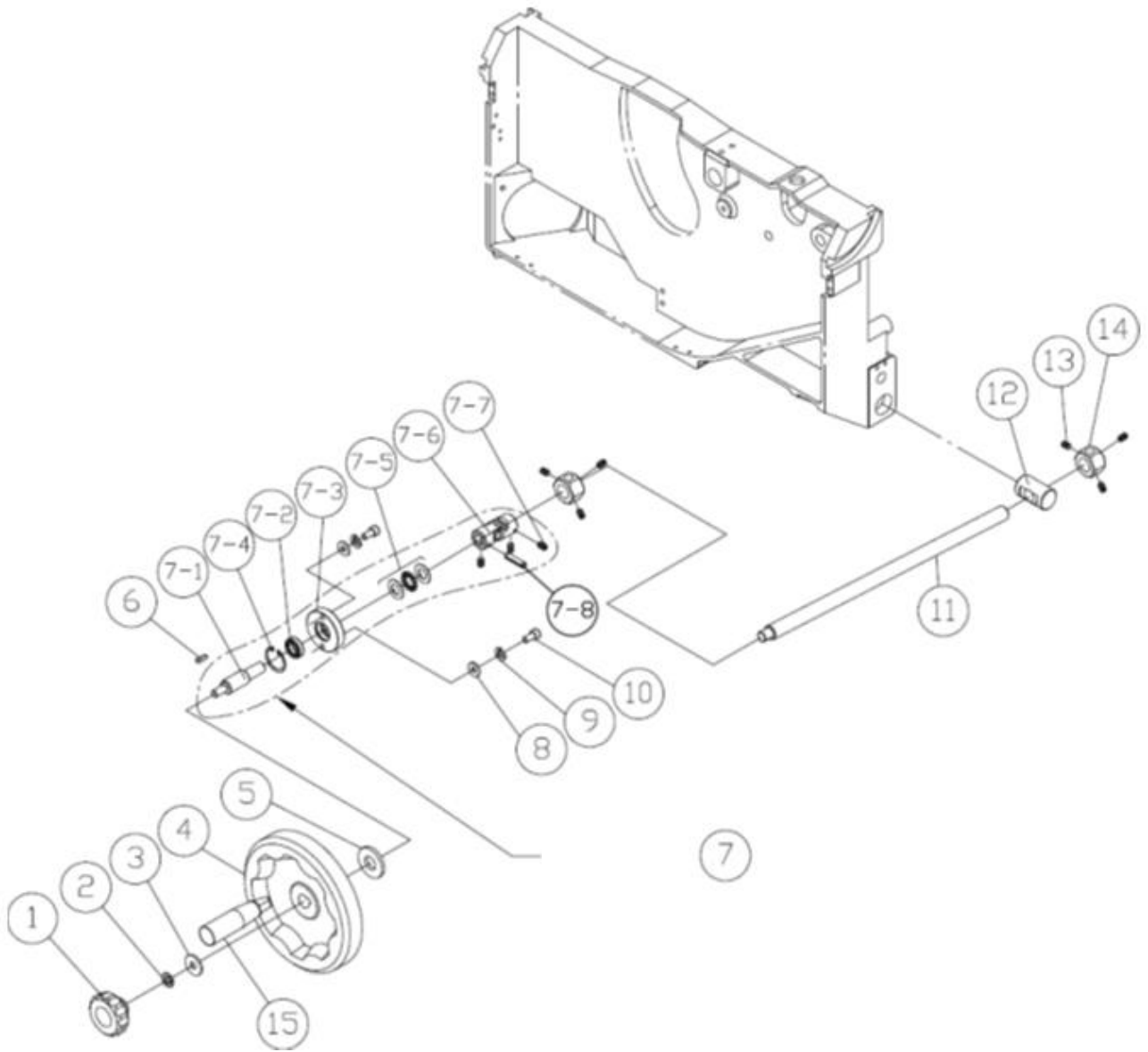

7.1 Parts list of Tilt & Elevation Hand-wheel Mechanism

Index No.	Part No.	Description	Size	Qty.
1	JTSS3200X2-701	Lock Knob	M10	1
2	TS-1550071	Flat Washer	M10	1
3	JTSS3200X2-703	Plastic Washer	M10×Ø27	1
4	JTSS3200X2-704	Tilt Hand Wheel		1
5	JTSS3200X2-705	Bearing Washer	T8	1
6	JTSS3200X2-706	Key	7x7x20	1
7	JTSS3200X2-707	Hand Wheel Shaft Assembly		1
7-1	JTSS3200X2-707-1	Hand Wheel Shaft		1
7-2	JTSS3200X2-707-2	Ball Bearing	6902ZZ	1
7-3	JTSS3200X2-707-3	Bearing Seat		1
7-4	JTSS3200X2-707-4	Ext. Retaining Ring	28 mm	1
7-5	JTSS3200X2-707-5	Trust Bearing	NTB1528 AS	1
7-6	JTSS3200X2-707-6	Universal Joint	Ø 14	1
7-7	TS-1523011	Socket Set Screw	M6×6	1
7-8	JTSS3200X2-707-8	Spring Pin	Ø6×Ø26	1
8	TS-2361081	Lock Washer	M8×Ø18	2
9	TS-2361081	Lock Washer	M8	2
10	TS-1504041	Socket Head Cap Screw	M8x20	2
11	JTSS3200X2-711	Tilt Lead Screw		1
12	JTSS3200X2-712	Trunnion with Lead Screw Connector		1
13	TS-1523011	Socket Set Screw	M6x6	6
14	JTSS3200X2-714	Tilt Lead Screw Nut		2
15	JTSS3200X2-715	Tilt Hand Wheel Bar		1

8.0 Exploded Drawing of Elevation Hand-wheel Mechanism

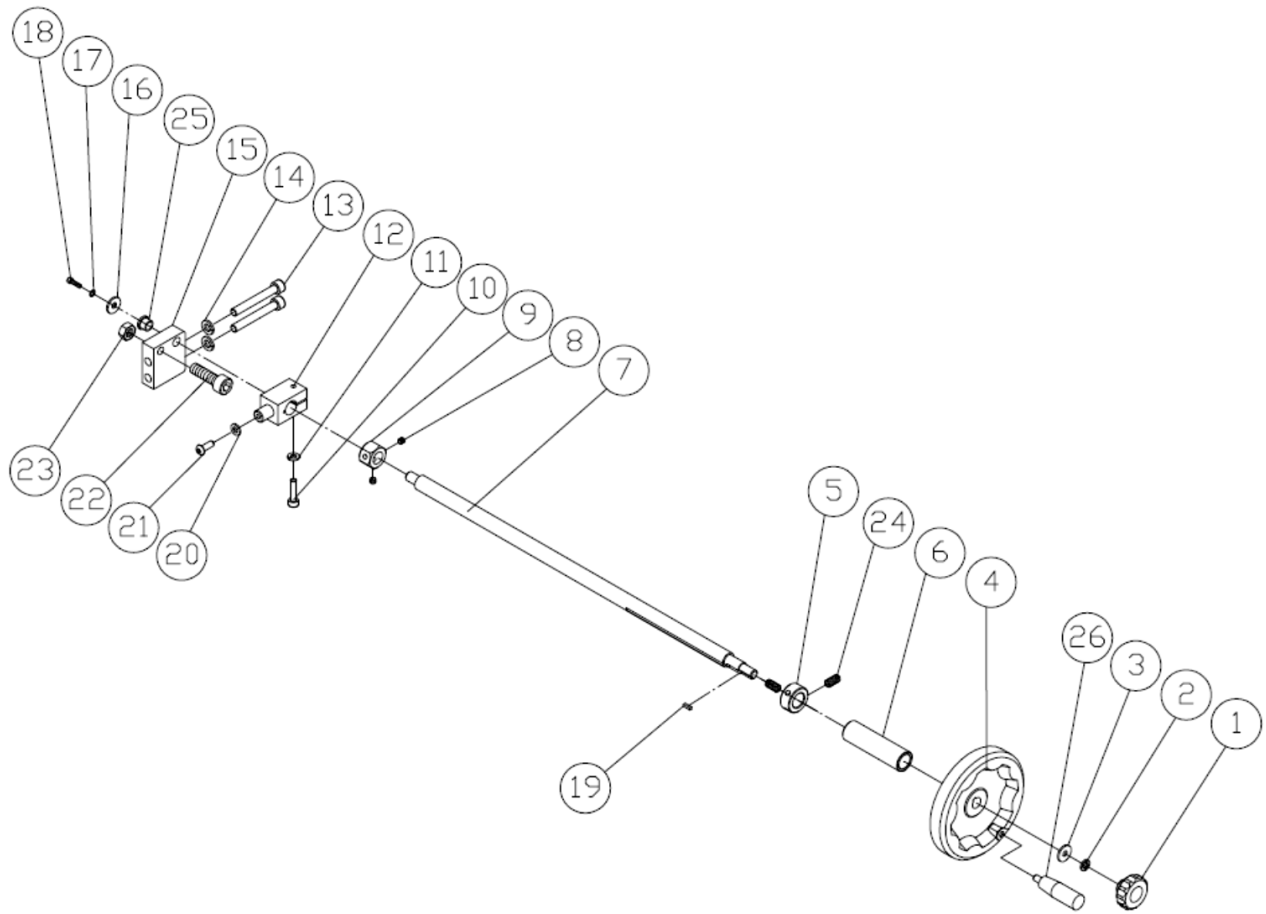

8.1 Parts List of Elevation Hand-wheel Mechanism

Index No.	Part No.	Description	Size	Qty.
1	JTSS3200X2-701	Lock Knob	M10	1
2	TS-1550071	Flat Washer	M10	1
3	JTSS3200X2-803	Plastic Washer	M10×Ø30	1
4	JTSS3200X2-804	Elevation Hand Wheel Assembly		1
5	JTSS3200X2-805	Lock Collar		1
6	JTSS3200X2-806	Lead Screw Sleeve		1
7	JTSS3200X2-807	Elevation Lead Screw		1
8	TS-1523011	Socket Set Screw	M6x6	3
9	JTSS3200X2-714	Elevation Lead Screw Nut		1
10	TS-1503071	Socket Head Cap Screw	M6x30	1
11	TS-2361061	Lock Washer	M6	2
12	JTSS3200X2-812	Elevation Lead Screw Clamp		1
13	TS-1504101	Socket Head Cap Screw	M8x50	2
14	TS-2361081	Lock Washer	M8	2
15	JTSS3200X2-815	Lead Screw Bracket		1
16	TS-1550041	Flat Washer	M6	1
17	TS-2361061	Lock Washer	M6	1
18	TS-1503031	Socket Head Cap Screw	M6x12	1
19	JTSS3200X2-819	Single Round Key	5x5x20	1
20	TS-1550041	Flat Washer	M6	1
21	TS-1503021	Socket Head Cap Screw	M6x10	1
22	TS-1505051	Socket Head Cap Screw	M10×35	1
23	TS-1540071	Hex. Nut	M10	1
24	TS-1523021	Socket Set Screw	M6x8	2
25	JTSS3200X2-825	Self-lubricating Bearing		1
26	JTSS3200X2-826	Tilt Hand Wheel Bar		1

9.0 Exploded Drawing of Scoring Blade Arbor & Adjustment Assembly

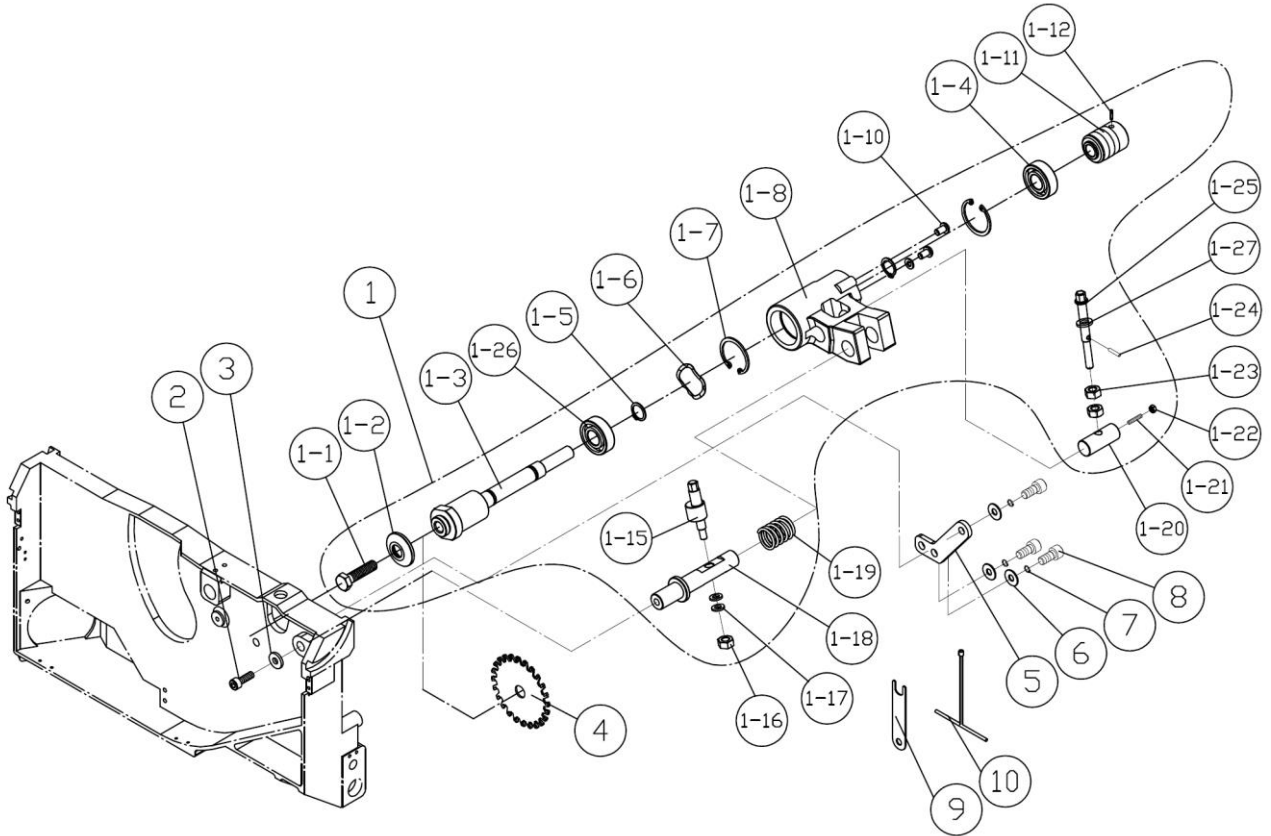

9.1 Parts List of Scoring Blade Arbor & Adjustment Assembly

Index No.	Part No.	Description	Size	Qty.
1	JTSS1600X2-901	Scoring Blade Arbor Assembly		1
1-1	SH120440	Hex. Cap Screw	M12x20	1
1-2	JTSS3200X2-901-2	Scoring Blade Arbor Flange		1
1-3	JTSS3200X2-901-3	Scoring Blade Arbor		1
1-4	BB-6202VV	Ball Bearing	6202LLB	1
1-5	JTS700-RS150000	Int. Retaining Ring	15 mm	2
1-6	JTSS3200X2-901-6	Wave Washer	Ø26xØ34 thk.0.3	1
1-7	JTSS3200X2-901-7	Int. Retaining Ring	35 mm	2
1-8	JTSS3200X2-901-8	Scoring Blade Arbor Housing		1
1-10	TS-1482021	Hex. Cap Screw	M6x12	2
1-11	JTSS1600X2-901-11	Scoring Blade Arbor Pulley		1
1-12	PS052500	Pin		1
1-13	TS-1550041	Flat Washer	M6	1
1-15	JTSS3200X2-901-15	Eccentric Shaft		1
1-16	TS-1541021	Hex. Nut Nylon Lock	M6	1
1-17	JTSS3200X2-901-17	Belleville Disc Spring	Ø15xØ6.2x0.5 thk. ...	2
1-18	JTSS3200X2-901-18	Horizontal Adjustment Shaft		1
1-19	JTSS3200X2-901-19	Compression Spring		1
1-20	JTSS3200X2-901-20	Vertical Adjustment Shaft		1
1-21	TS-1523071	Socket Set Screw	M6x25	1
1-22	TS-1540041	Hex. Nut	M6	1
1-23	TS-1540061	Hex. Nut	M8	2
1-24	JTSS3200X2-901-24	Roll Pin	Ø2.5x12	1
1-25	JTSS3200X2-901-25	Vertical Adjustment Bolt		1
1-26	BB-600304	Ball Bearing	6003LLB	1
1-27	TS-1550061	Flat Washer	M8	1
2	TS-1504041	Socket Head Cap Screw	M8x20	1
3	WF083030	Flat Washer	M8x Ø30	1
4	JTSS3200X2-904	Scoring Saw Blade	Ø20	1
5	JTSS3200X2-905	Pivot Arm		1
6	TS-1550041	Flat Washer	M6	3
7	TS-2361061	Lock Washer	M6	3
8	TS-1503041	Socket Head Cap Screw	M6x16	3
9	JTSS3200X2-909	Wrench		1
10	JTSS3200X2-910	T Screw Driver	8 mm	1

10.0 Exploded Drawing of Swing Arm Assembly

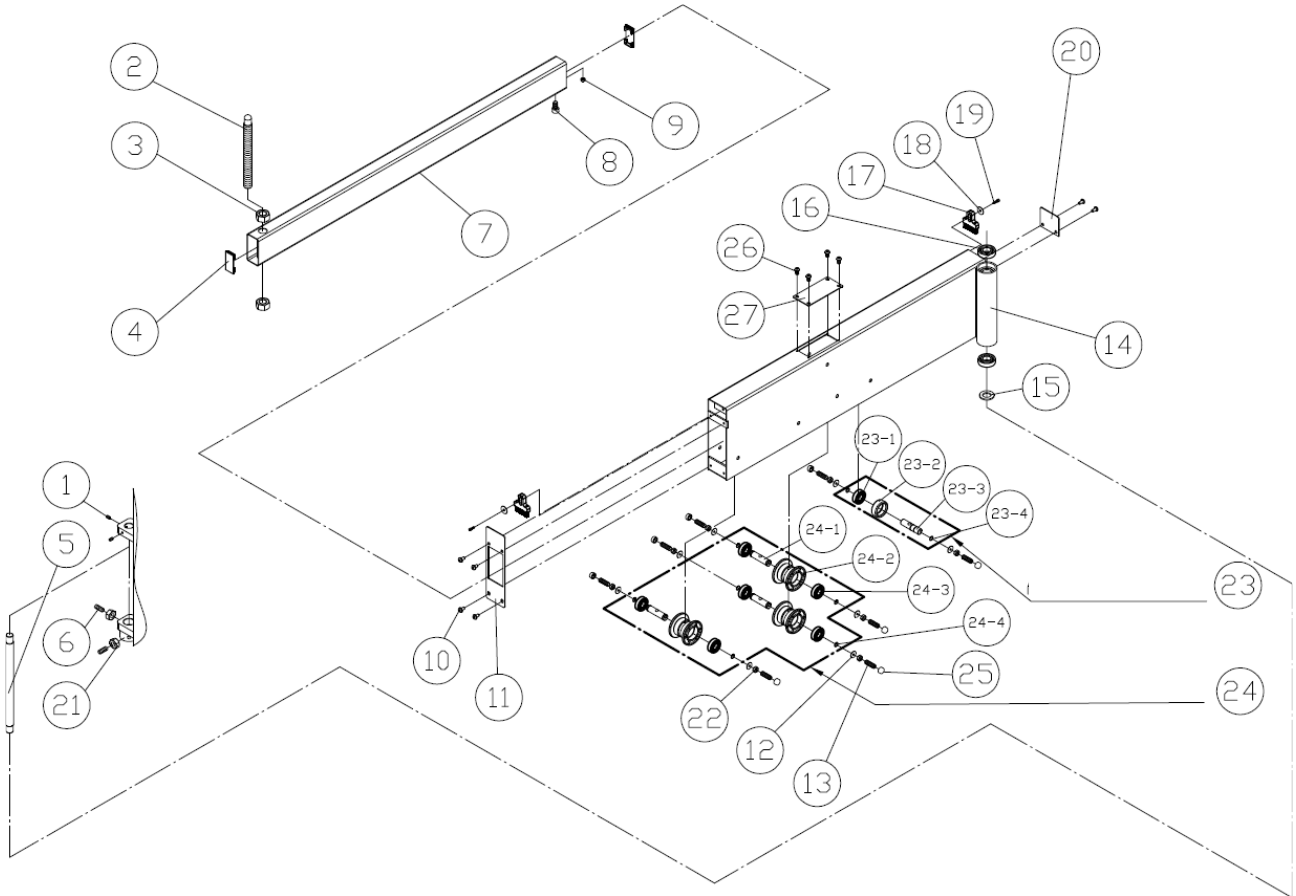

10.1 Parts List of Swing Arm Assembly

Index No.	Part No.	Description	Size	Qty.
1	TS-1525011	Socket Set Screw	M10x10	3
2	JTSS1600X2-1002	Crosscut Frame Rotary Pivot		1
3	NH203000	Hex. Nut	M20x2.5P	1
4	JTSS1600X2-1004	Sliding Tube End Plug	40x80 mm	2
5	JTSS1600X2-1005	Swing Arm Pivot Shaft		1
6	TS-1525041	Socket Set Screw	M10x20	4
7	JTSS1600X2-1007	Sliding Tube	1600 mm	1
8	TS-1504041	Socket Head Cap Screw	M8x20	1
9	TS-1540061	Hex. Nut	M8	2
10	TS-2246102	Socket Button Head Screw	M6x10	6
11	PMPS-1600-1011	Swing Arm Cover Plate		1
12	TS-1550061	Flat Washer	M8	8
13	TS-1524061	Socket Set Screw	M8x25	8
14	PMPS-1600-1014	Swing Arm		1
15	TS-1550111	Flat Washer	M20	1
16	BB-6004ZZ	Ball Bearing	6004ZZ	1
17	JTSS1600X2-1017	Brush		2
18	TS-1550041	Flat Washer	M6	2
19	TS-1503051	Socket Head Cap Screw	M6x20	2
20	PMPS-1600-1127	Brush Cover		1
21	TS-1540071	Hex. Nut	M10	4
22	TS-1540061	Hex. Nut	M8	2
23	JTSS3200X2-1118	Bearing Shaft Assembly		1
23-1	BB-6202ZZ	Ball Bearing	6202ZZ	1
23-2	JTSS3200X2-1118-2	Bearing Spacer		1
23-3	JTSS3200X2-1118-3	Bearing Shaft		1
23-4	JTS700-RS150000	Ext. Retaining Ring	15 mm	2
24	JTSS3200X2-1115	Swing Arm Roller Assembly		3
24-1	JTSS3200X2-1115-1	Swing Arm Roller Axle		1
24-2	JTSS3200X2-1115-2	Swing Arm Roller		1
24-3	BB-6202ZZ	Ball Bearing	6202ZZ	2
24-4	JTSS3200X2-1115-4	Ext. Retaining Ring	15 mm	2
25	JTSS3200X2-1135	Cover Nut	13 mm	8
26	SJ059200	Socket Button Head Screw	M5x8	4
27	PMPS-1600-1137	Awing Arm Top Plate		1

12.0 Exploded Drawing of Crosscut Table Assembly

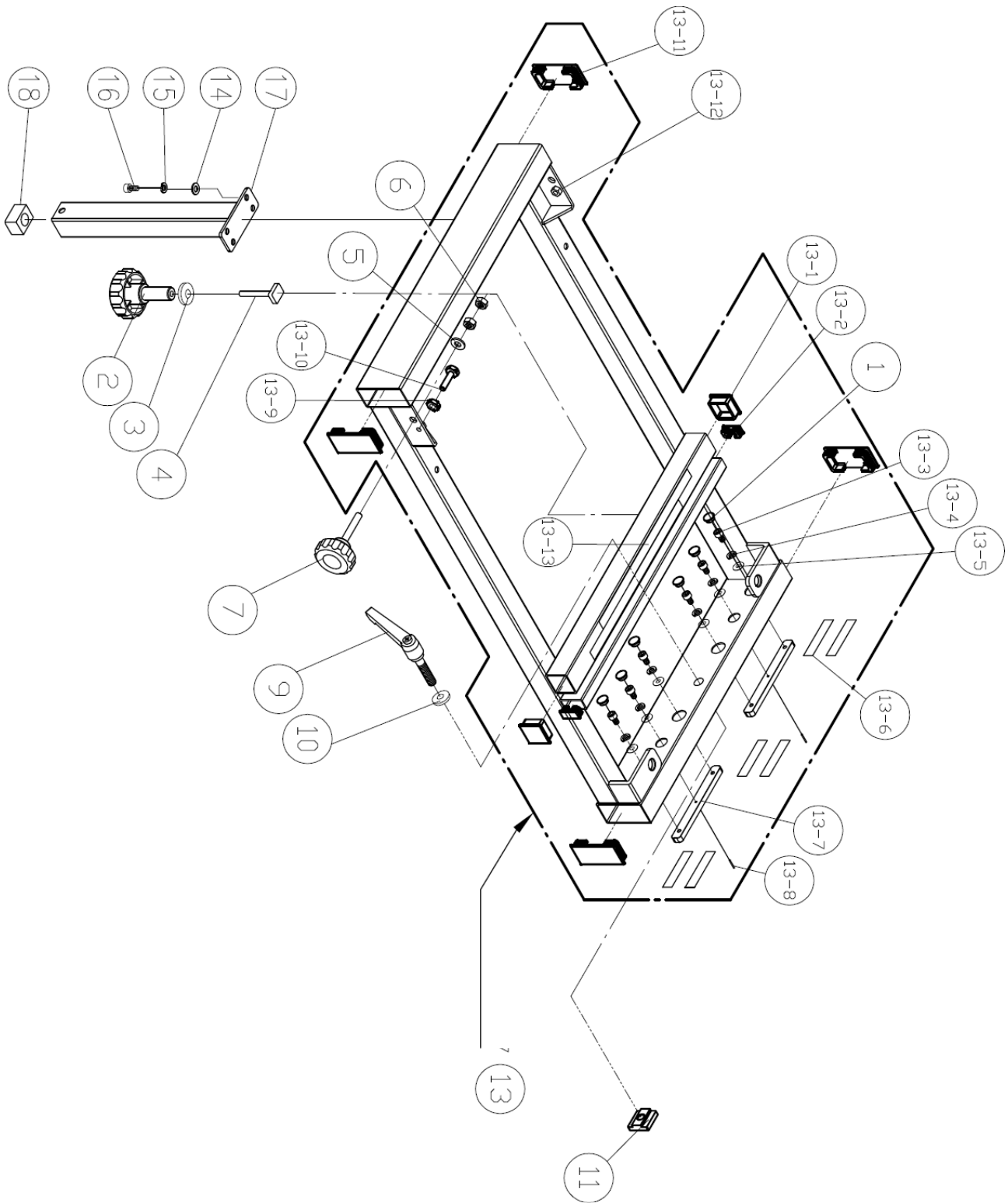

12.1 Parts List of Crosscut Table Assembly

Index No.	Part No.	Description	Size	Qty.
1	JTS700-813	Round Plug		6
2	JTSS1600X2-1202	Knob Screw	M8x55L	1
3	TS-1550061	Flat Washer	M8	1
4	JTSS1600X2-1204	T Lock Bar		1
5	TS-1550061	Flat Washer	M8	1
6	TS-1540061	Hex. Nut	M8	2
7	JTS700-809	Knob Screw	M8x50L	1
9	JTS700-808	L Lock Handle	M12x57Lx1.75P	1
10	TS-2360121	Flat Washer	M12	1
11	JTSS1600X2-1211	Nut Block		1
13	JTSS1600X2-1213	Crosscut Table Frame Assembly		1
13-1	JTSS1600X2-1213-1	End Plug	38x38 mm	2
13-2	JTSS1600X2-1213-2	End Plug	40x20 mm	2
13-3	TS-2246162	Socket Button Head Screw	M6x16	6
13-4	TS-2361061	Lock Washer	M6	6
13-5	TS-1550041	Flat Washer	M6	6
13-6	JTSS3200X2-1208-10	Cushion	55 mm	6
13-7	JTS700-803	Slide T-Bar		2
13-8	JTSS1600X2-1213-8	Pin	3x14	2
13-9	TS-1540061	Hex. Nut	M8	2
13-10	TS-1490051	Hex. Cap Screw	M8x30	2
13-11	JTS700-814	Cross Table Frame End Plug	40x80 mm	4
13-12	PMPS-1600-1213-12	Cross Table Frame		1
13-13	JTSS1600X2-1213-13	Scale		1
14	TS-1550041	Flat Washer	M6	4
15	TS-2361061	Lock Washer	M6	4
16	TS-1503041	Socket Head Cap Screw	M6x16L	4
17	PMPS-1600-1217	Square Brace		1
16	JTSS1600X2-1218	Brace End Plug		1

13.0 Exploded Drawing of Crosscut Table Extension Fence Assembly

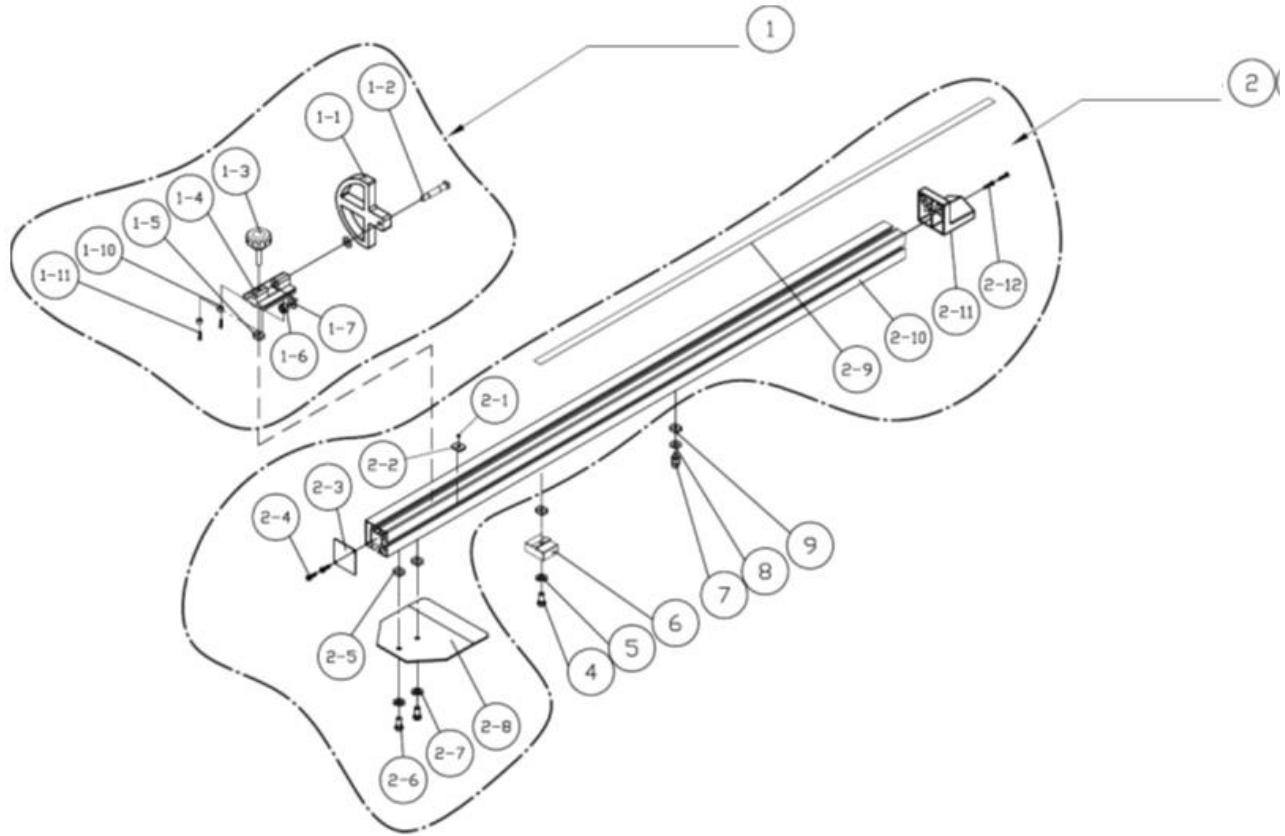

13.1 Parts List of Crosscut Table Extension Fence Assembly

Index No.	Part No.	Description	Size	Qty.
1	JTS700-1022	Flip Stop Assembly		2
1-1	JTSS3200X2-1301-1	Flip Stop		1
1-2	JTSS3200X2-1301-2	Flip Stop Pivot Shaft		1
1-3	JTSS3200X2-1301-3	Knob Screw	M8x40Lx1.25P	1
1-4	JTSS3200X2-1301-4	Flip Stop Bracket		1
1-5	JTS700-1021	T-Nut	M8x1.25P	1
1-6	TS-1541041	Hex. Nut Nylon Lock	M10	1
1-7	JTSS3200X2-1301-7	Copper Washer	Ø11xØ18x0.5 thk.	2
1-10	JTSS3200X2-1301-10	Ring Spacer		2
1-11	JTSS3200X2-1301-11	Cup Screw	M3x12	2
2	JTSS1600X2-1302	Extension Fence Assembly		1
2-1	JTS700-SS050100	Socket Set Screw	M5x5	1
2-2	JTSS3200X2-1302-15	Nut		2
2-3	JTSS3200X2-1302-3	Extension Fence End Cover Plate		1
2-4	ST040200	Tap Screw	M4x10	2
2-5	JTS700-1021	T-Nut	M8x1.25P	1
2-6	TS-2248162	Socket Button Head Screw	M8x16	2
2-7	TS-2361081	Lock Washer	M8	2
2-8	JTSS3200X2-1302-7	Extension Fence Locate Plate		1
2-9	JTSS1600X2-1302-09	Extension Fence Scale	0~2000 mm	1
2-10	JTSS3200X2-1302-12	Crosscut Fence		1
2-11	JTS700-206424	Extension Fence End Plug		1
2-12	TS-1532032	Pan Head Screw	M4x10	2
4	TS-1504071	Socket Head Cap Screw	M8x35	1
5	TS-2361081	Lock Washer	M8	1
6	JTSS3200X2-1309	T-Block		1
7	JTSS1600X2-1307	Pivot Shaft		1
8	JTSS3200X2-1305	Fiber Flat Washer	M10	1
9	JTS700-1021	T-Nut	M8x1.25P	2

14.0 Exploded Drawing of Rip Fence Assembly

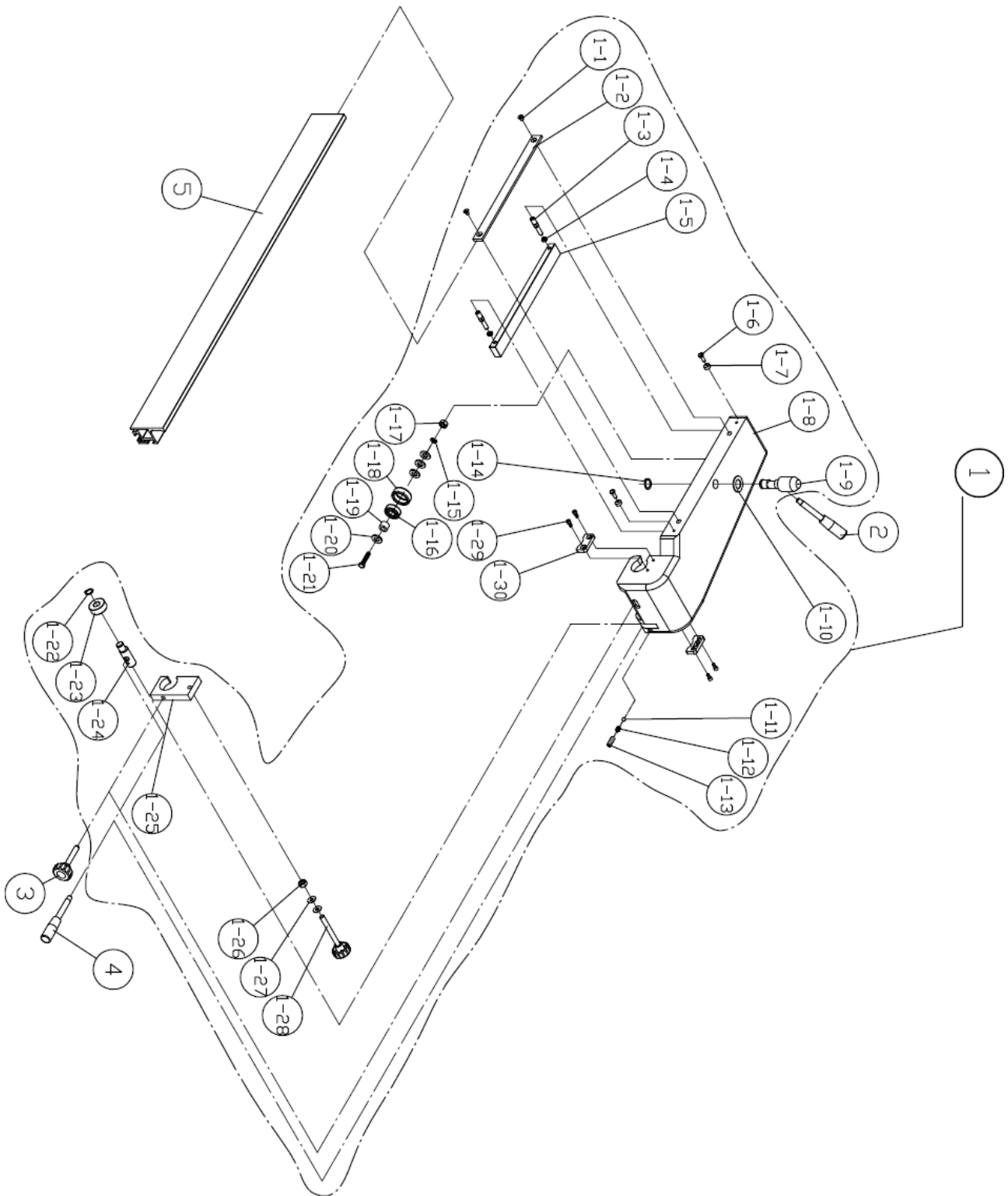

14.1 Parts List of Rip Fence Assembly

Index No.	Part No.	Description	Size	Qty.
1	JTSS3200X2-1401	Rip Fence Head Assembly		1
1-1	JTS700-SI069400	Counter Sunk Screw	M6x16	2
1-2	JTS700-206433	Clamp Lock Plate		1
1-3	JTS700-203193	Eccentric Shaft		2
1-4	TS-1541031	Hex. Nut Nylon Lock	M8	2
1-5	JTS700-200875	Rip Fence Seat Plate		1
1-6	TS-1482031	Hex. Cap Screw	M6x16	2
1-7	JTS700-203179	Eccentric Ring		2
1-8	PMP5-3200-206422	Rip Fence Casting Seat		1
1-9	JTS700-203213	Fence Sliding Lock Knob (Eccentric Shaft)		1
1-10	TS-1550111	Flat Washer	M20	1
1-11	JTS700-994181	Steel Ball	Ø8	1
1-12	JTS700-150099	Compression Spring		1
1-13	TS-1525011	Socket Set Screw	M10x10	1
1-14	JTS700-RS200000	Int. Retaining Ring	20 mm	1
1-15	TS-2361081	Lock Washer	M8	1
1-16	BB-6202ZZ	Ball Bearing	6202ZZ	1
1-17	TS-1540061	Hex. Nut	M8	1
1-18	JTS700-203356	Busing Ring	M8	1
1-19	JTS700-206435	Pad Ring		1
1-20	TS-1550061	Flat Washer	M8	4
1-21	TS-149006	Hex. Cap Screw	M8x35	1
1-22	JTS700-RS150000	Int. Retaining Ring	15 mm	1
1-23	JTS700-203649	Bushing Ring		1
1-24	JTS700-203650	Handle shaft		1
1-25	JTS700-206428	Rip Fence Rail Bracket		1
1-26	TS-1541041	Hex. Nut Nylon Lock	M10	1
1-27	TS-1550071	Flat Washer	M10	2
1-28	JTS700-205114	Adjust Knob Screw	M10x110	1
1-29	TS-1503021	Socket Head Cap Screw	M6x10	4
1-30	JTS700-205822	Way Wiper (Scraper)		2
2	JTS700-200884	Fence Sliding Lock Knob Handle		1
3	JTS700-206432	Knob Screw	M10x55Lx1.5P	1
4	JTS700-200884	Lock Down Handle		1
5	JTS700-205663	Rip Fence Profile	1 M	1

15.0 Exploded Drawing of Sliding Table Assembly

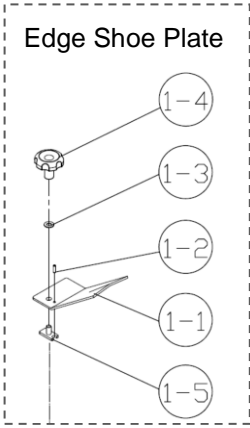
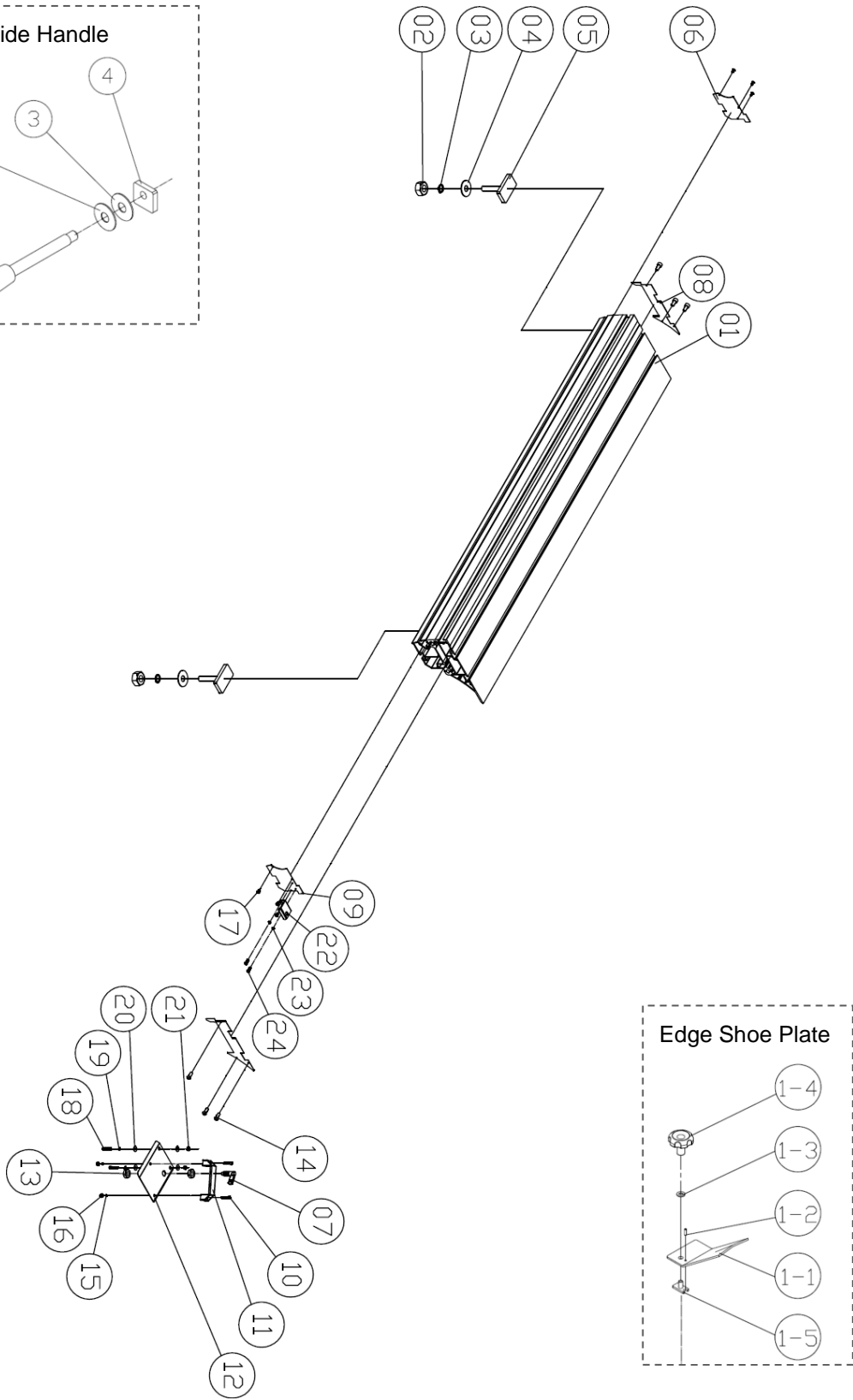
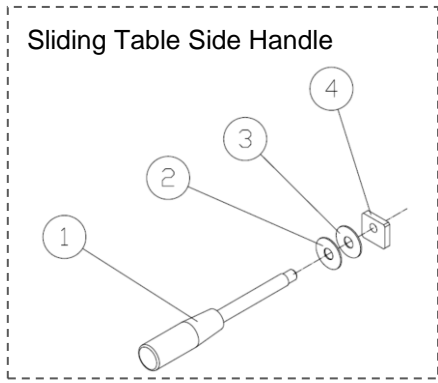

15.1 Parts List of Sliding Table

Index No.	Part No.	Description	Size	Qty.
1	JTSS3200X2-1501-201	Sliding Table Set	1600x316 mm	1
2	NH121900	Hex. Nut	M12x1.75P	2
3	TS-2361121	Lock Washer	M12	2
4	TS-2360121	Flat Washer	M12	3
5	JTSS1600x2-1505	T-Bolt	M12x60x1.75P	3
6	PMPS-1600-1506	End Cover Plate		1
7	JTSS1600x2-1507	Pin Lock		1
8	PMPS-1600-1508	Sliding table Left End Cover Plate		1
9	PMPS-1600-1509	Sliding table Right End Cover Plate		1
10	TS-1504031	Socket Head Cap Screw	M8x16	2
11	JTSS1600x2-1511	Handle		1
12	PMPS-1600-1512	Sliding table Right Locate Plate		1
13	JTSS1600X2-1513	Hex Nut	M16xP1.5	2
14	TS-2245122	Socket Head Button Screw	M5x12	6
15	TS-2361081	Lock Washer	M8	2
16	TS-1540061	Hex. Nut	M8	2
17	ST049300	Tapping Screw	M4x12	6
18	TS-2246162	Socket Head Button Screw	M6x16	2
19	TS-2361061	Lock Washer	M6	2
20	TS-1550041	Flat Washer	M6	4
21	TS-1540041	Hex. Nut	M6	2
22	JTSS1600X2-1522	Locate Plate	M4x12	6
23	TS-2361061	Lock Washer	M6	2
24	TS-2246122	Socket Head Button Screw	M6x12	2

15.2 Parts List of Sliding Table Side Handle

Index No.	Part No.	Description	Size	Qty.
	JTSS3200X2-AB200939	Sliding Table Side Handle Assembly		1
1	JTSS3200X2-1501	Handle		1
2	TS-2360121	Flat Washer	M12	1
3	JTSS3200X2-1503	Plastic Washer	M13xØ25x2 thk.	1
4	JTSS3200X2-1504	T-Nut	M12x1.75P	1

15.3 Parts List of Edge Shoe Plate Assembly

Index No.	Part No.	Description	Size	Qty.
	JTSS3200X2-AB201830	Edge Shoe Assembly		1
1-1	JTSS3200X2-1501-1	Edge Shoe Plate		1
1-2	JTSS3200X2-1501-2	Pin	Ø5xØ18	1
1-3	TS-1550071	Flat Washer	M10	1
1-4	JTSS3200X2-1501-4	Knob Screw	M10	1
1-5	JTSS3200X2-1501-5	T-Nut	M10x1.5P	1

15.4 Exploded Detail Drawing of 1.6M Sliding Table Assembly

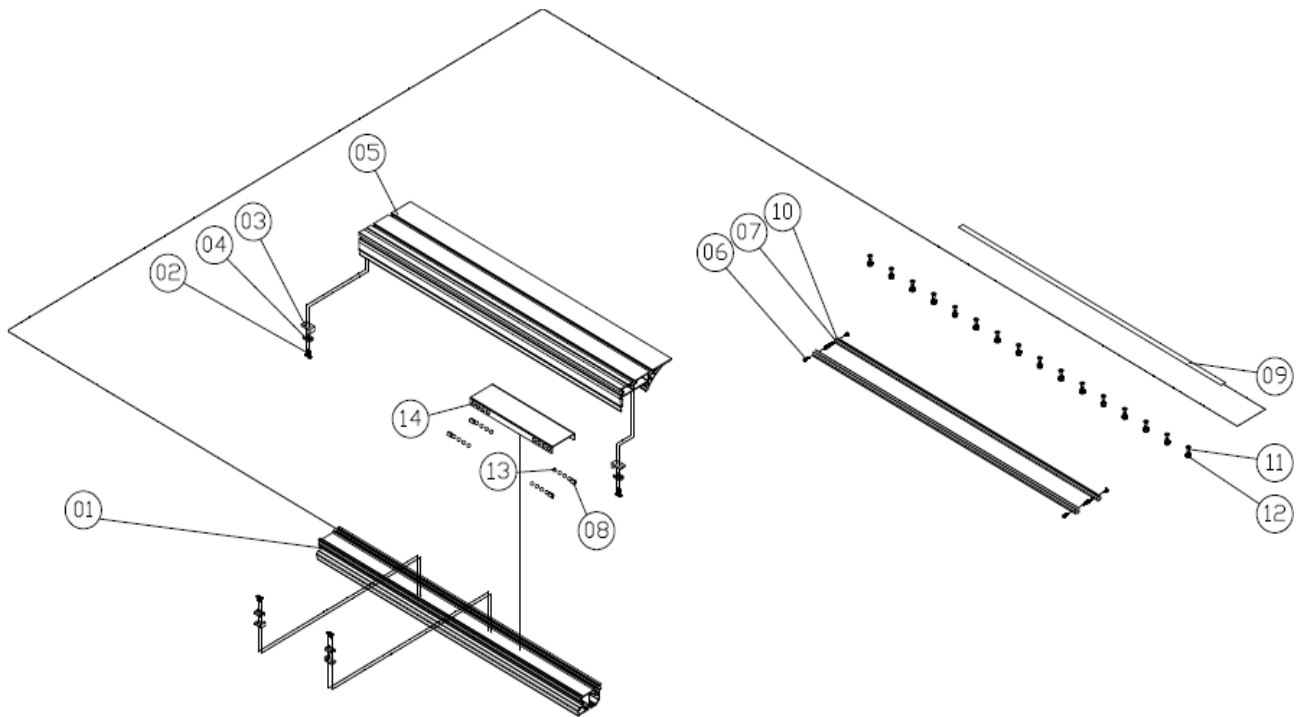

15.5 Parts List of Detail Drawing of 1.6M Sliding Table Assembly

Index No.	Part No.	Description	Size	Qty.
1	2316160S-2	Sliding Table Bottom Base	1600 mm	1
2	TS-1514051	Socket Head Flat Screw	M6x30	8
3	2316160S-14	Rubber Block		4
4	2316160S-12	Locate Block Plate		4
5	2316160S-1	Sliding Table	1600 mm	1
6	TS-2246102	Socket Head Button Screw	M6x10	8
7	2316160S-11	Sliding Table Way		8
8	2316160S-15	Wool Pad		4
9	2316160S-8	Cover Strip		1
10	2316160S-4	Way Adhesive Strip		8
11	SM100400	Socket Head Flat Screw	M10x20	16
12	TS-1541041	Hex. Nut Nylon Lock	M10	16
13	2360320E-17	Hardened Steel Ball	φ 16.6	16
14	2316160S-16	Slide Plate		1

16.0 Exploded Drawing of Saw Blade Guard Assembly

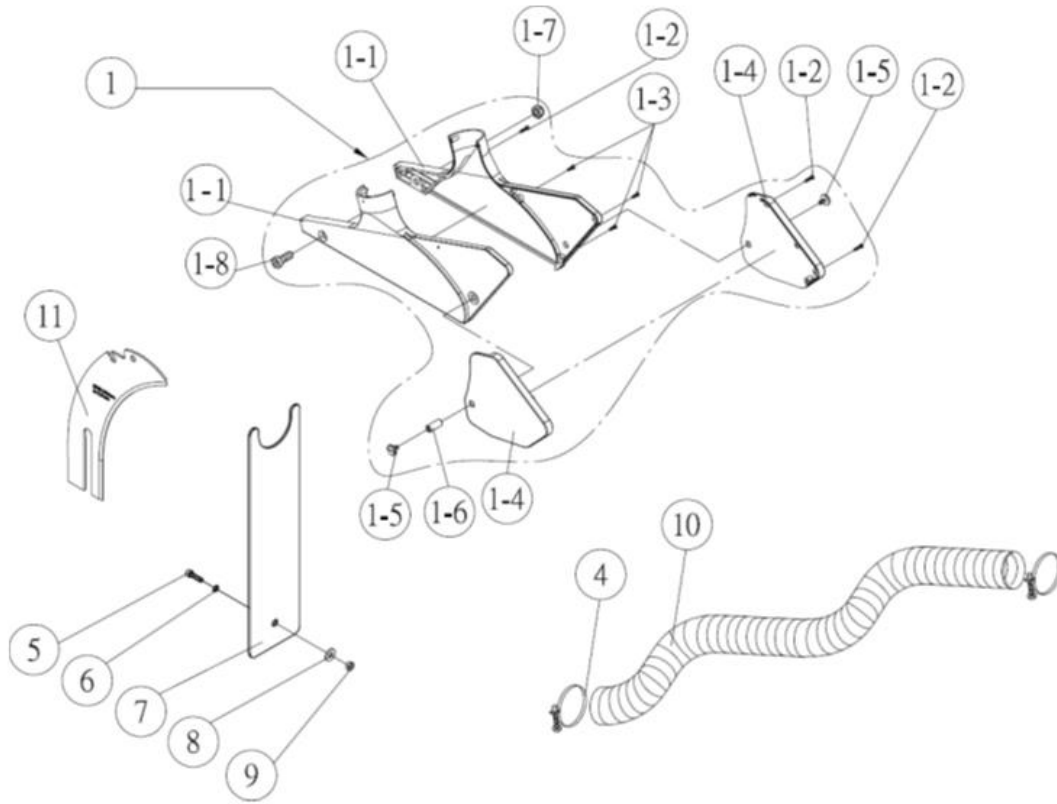

16.1 Parts List of Saw Blade Guard Assembly

Index No.	Part No.	Description	Size	Qty.
1	JTSS3200X2-1601	Blade Guard Assembly		1
1-1	JTSS3200X2-1601-1	Main Blade Guard		1
1-2	ST029404	Tap Screw	M3x16	3
1-3	ST029304	Tap Screw	M3x12	3
1-4	JTSS3200X2-1601-4	Scoring Blade Guard		1
1-5	203110	Scoring Guard Pivot Screw	M5x10	2
1-6	JTSS3200X2-1601-6	Pivot Sleeve		1
1-7	TS-1541041	Hex. Nut Nylon Lock	M10	1
1-8	205162	Socket Head Cap Screw (special size)	M10x25	1
5	TS-1505031	Socket Head Cap Screw	M10x25	1
6	TS-2361101	Lock Washer	M10	1
7	JTS700-206422	Dust Hose Support Plate		1
8	TS-1550071	Flat Washer	M10	1
9	TS-1541041	Hex. Nut Nylon Lock	M10	1
11	JTSS3200X2-1611	Riving Knife		1

17.0 Exploded Drawing of Hold-Down Assembly

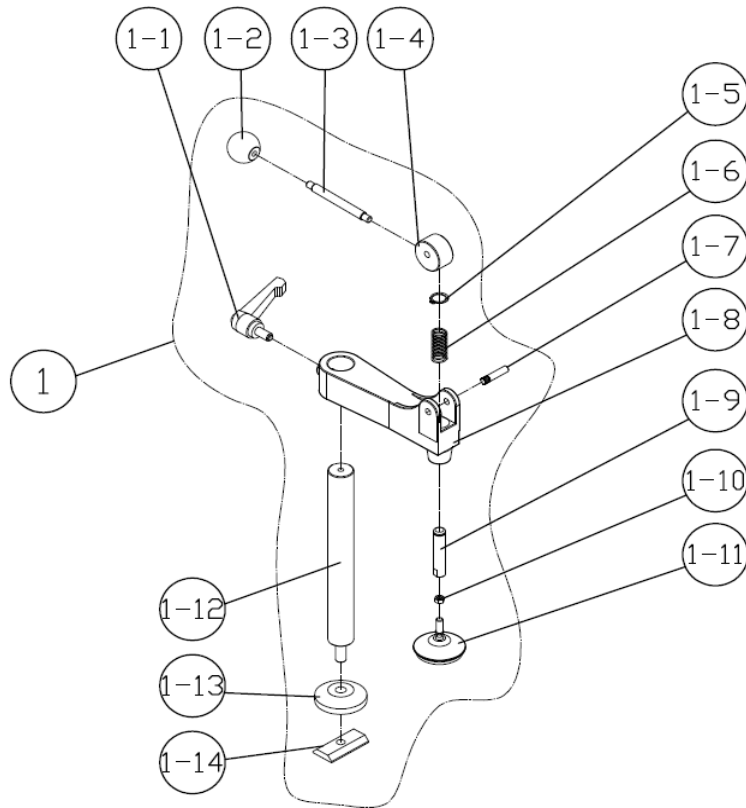

17.1 Parts List of Hold-Down Assembly

Index No.	Part No.	Description	Size	Qty.
1	JTSS3200X2-1701	Hold Down-Press Assembly		1
1-1	JTSS3200X2-1701-1	L Lock Handle screw		1
1-2	JTSS3200X2-1701-2	Down-Press Ball Handle		1
1-3	JTSS3200X2-1701-3	Down-Press Handle bar		1
1-4	JTSS3200X2-1701-4	Down Press Cam		1
1-5	JTSS3200X2-1701-5	Ext. Retaining Ring	14 mm	1
1-6	JTSS3200X2-1701-6	Down-Press Spring		1
1-7	JTSS3200X2-1701-7	Down-Press Cam shaft		1
1-8	JTSS3200X2-1701-8	Down-Press Bracket		1
1-9	JTSS3200X2-1701-9	Push Plate Arbor		1
1-10	TS-0570021	Hex. Nut	5/16-18	1
1-11	JTSS3200X2-1701-11	Push Plate		1
1-12	JTSS3200X2-1701-12	Down-Press Bracket Arbor		1
1-13	JTSS3200X2-1701-13	Down-Press Bushing		1
1-14	JTSS3200X2-1701-14	Down-Press Fix Block		1

Circuit Diagram P MPS-1600... P MPS-1600...1~230V, 50Hz

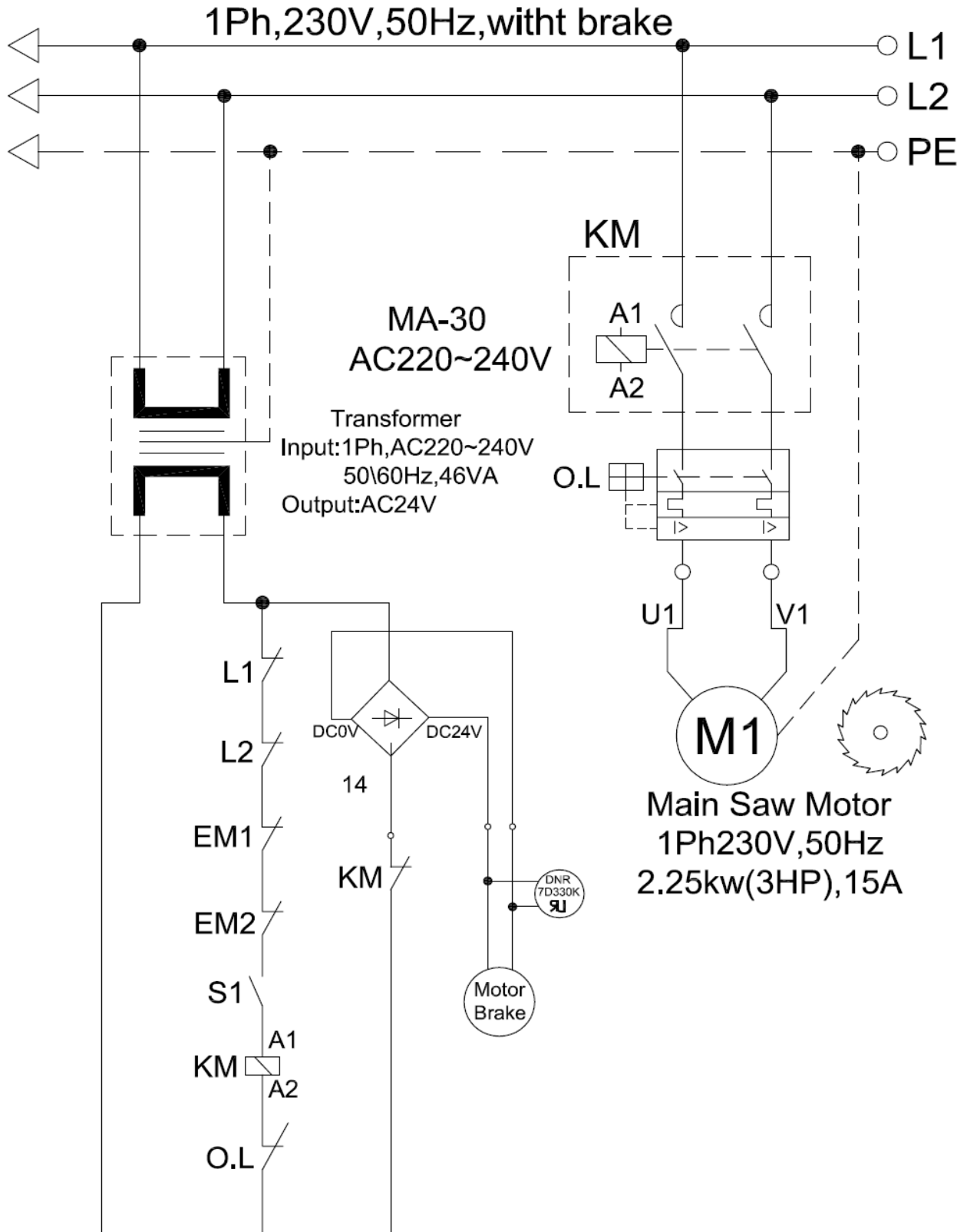

Circuit Diagram PMP5-1600... PMP5-1600-3...3~400V, 50Hz

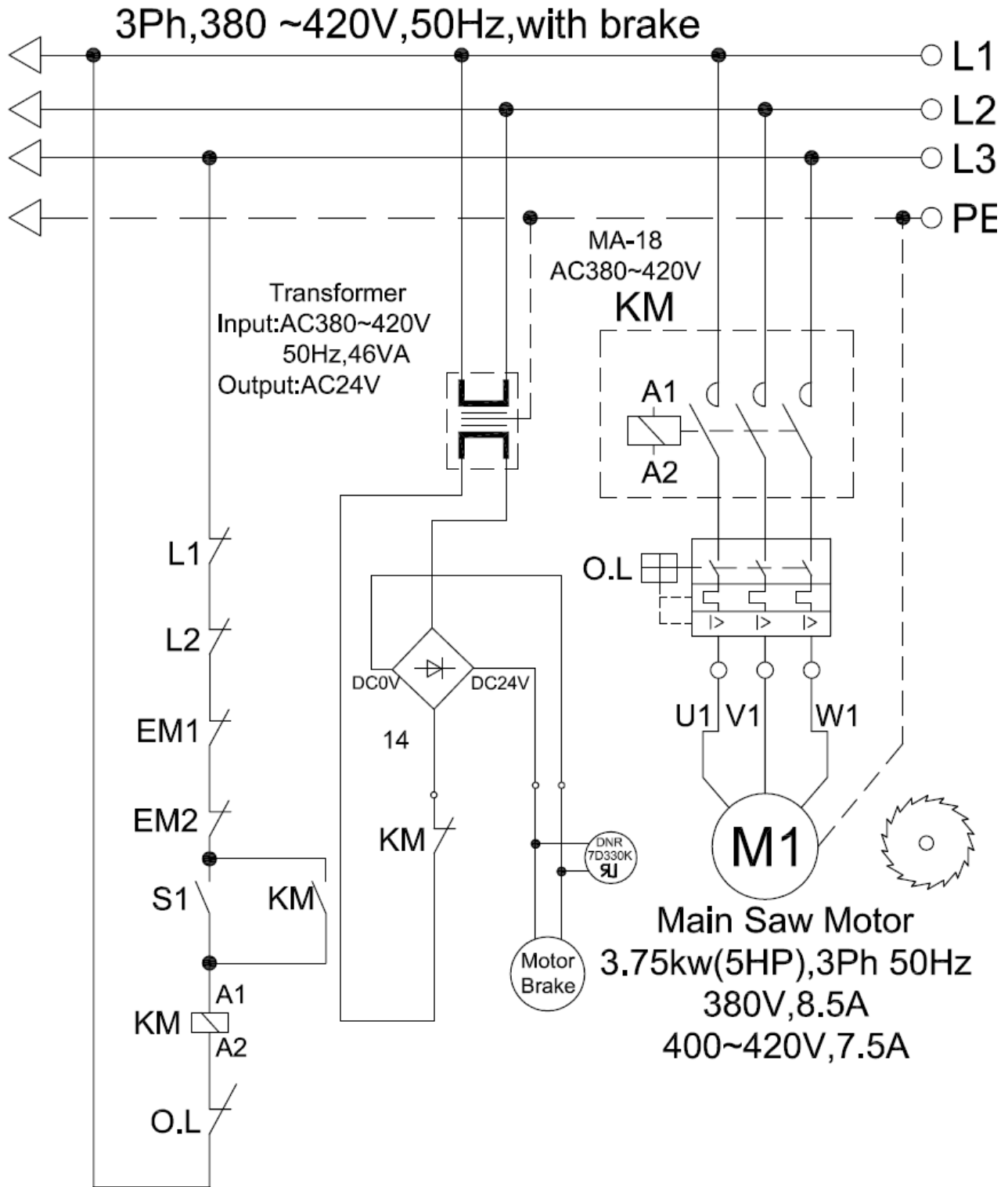

Remark:

Symbol	Meaning of Symbol
L1 L2	Back Door Limit Switch Blade Cover Limit Switch
O.L	Main Saw Blade Motor Overload
EM1 EM2	Panel Emergency Stop Switch Machinery Emergency Stop Switch
S1	Main Saw Stop Button Switch
HL	Power Light (AC 24V)
M1	Main Saw Blade Motor
KM	Magnet Contactor for Main Saw Blade motor